

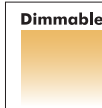

VSK6NC

120~277VAC LED 6", Non-IC, Commercial
LED Down Light with New Construction Frame

6" Commercial LED



CA
Title 24

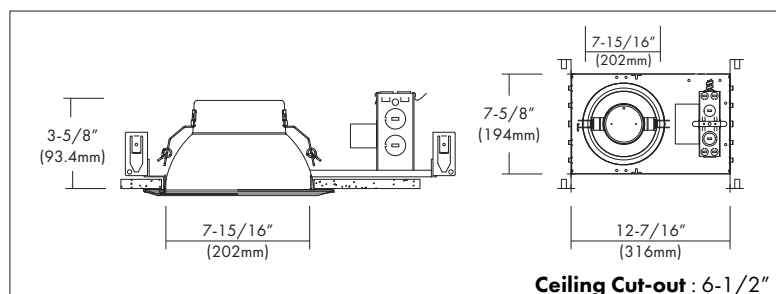

Ceiling Cut-out : 6-1/2"

DESCRIPTION

The VSK6NC is a 6" Commercial grade, DoB, AC Direct LED, Recessed Downlight for New Construction. Designed for use in non-insulated ceilings, Insulation material must be kept a minimum of 3" from fixture. It has an integral one-piece LED housing that is installed into the New Construction Frame. Available with a 15W, 20W or 30W high efficacy Universal voltage, DoB LED module with Triac, ELV and 0-10V dimming. The optical diffuser produces high lumen transmission and even illumination. Suitable for Damp Locations.

DESIGN FEATURES

Mounting Frame

- Galvanized steel construction.
- Housing adjusts for ceilings up to 1-1/4" thick.

Junction Box

- Listed for through branch circuit wiring. (Max.8 No 12 AWG 90°C branch circuit conductors: 4 in, 4 out).
- (5) 1/2" knockouts with pry-out slots and (4) knockouts with Romex cable clamps.
- Ground wire provided on J-box.

Hanger Bars

- 24" Bar Hangers provide stability and support on joists and T-Bar Grid ceilings.
- Housing can be positioned at any point within 24" joist spacing.
- Score lines allow easy "bend & snap-off" shortening for 12" joist spacing.

LED Fixture

- Heavy gauge, painted aluminum reflector allows for efficient heat dissipation.
- Universal 120-277VAC Non-Isolated DoB LED module with Tri-dimming of Triac, ELV and 0-10V in one module. Warning: Non-Isolated DoB fixtures cannot use 0-10V Electronic Relay Systems without incurring damage. For those type of Electronic Dimming systems, order the Optional Isolation 0-10V Dongle: DONGLE-ISO1.0. 1 Dongle is used for each fixture dimmed.
- White Powder Coat paint is standard. Consult factory for other finish colors.

Listing

- cCSA-us, Damp Locations
- California Title 24
- ENERGY STAR

Limited Warranty

- LED Module: 5 years/50K hours

SPECIFICATION

LED Quantity	1EA		
Input Voltage	120V~277V AC		
Wattage (Typ)	15W	20W	30W
Lumen (Typ)	900	1,200	1,800
Efficacy (LPW)	60 lm/W	60 lm/W	60 lm/W
Beam Angle	80°	80°	80°
CRI (Typical)	80		
Color (+/-5%)	3000K, 3500K, 4000K		
Dimming	Triac, ELV, 0~10V**		
Environment	Indoor Damp Location		

Triac Approved Dimmers

- * Lutron Skylark S Series
- * Lutron Diva DVCL Series
- * Lutron Ariadni AYCL Series
- * Leviton Illumatech IPI10 Series
- * Leviton Trimatron 705 Series

ELV Approved Dimmers

- * Lutron Skylark SELV Series
- * Lutron Diva DVELV Series
- * Lutron Maestro MAELV Series
- * Lutron Maestro MRF2-6ELV Series
- * Lutron Nova NTELV Series
- * Leviton IPE04 Series

0-10V Approved Dimmers**

- * Lutron Nova NTFTV Series
- * Lutron Diva DDTV Series
- * Lutron Diva DVSTV Series
- * Leviton Decora IP71 ODL Series

**** WARNING: DO NOT USE 0-10V Electronic Relay Systems like Acuity nPP16 EFP or Creston GLXP-DIMFLV8-LP units with Lum-Tech DoB fixtures. If you want to use a 0-10V Electronic Relay System, order the optional DONGLE-ISO1.0 which will prevent damage to the fixtures.**

* Provided: Easy-quick connector case
US Patent 8,882,308



Options

- Dongle

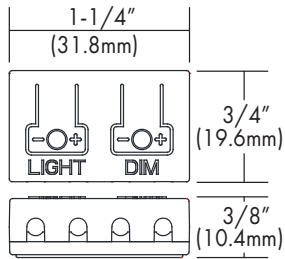

0-10V Isolation Dongle Wiring Diagram for Electronic 0-10V Relay Systems

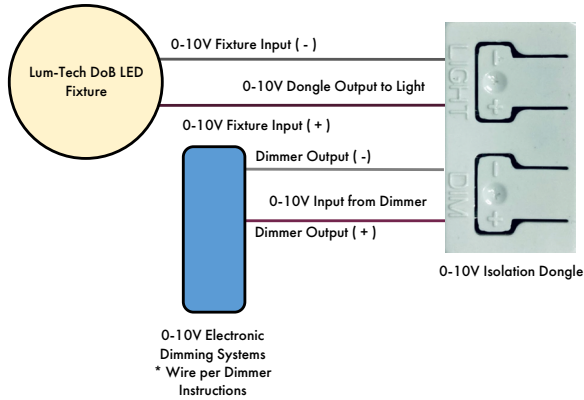

Ordering Information

Model

VSFK6NC = 120-277VAC DoB LED 6", Non-IC
Down Light with New Construction Frame

-Watts

- 15 = 15W
- 20 = 20W
- 30 = 30W

-CRI

- 8 = 80

Color Temp. **

- 30 = 3000K
- 35 = 3500K
- 40 = 4000K

Reflector Finish*

HC = Haze Clear (Standard)

Trim Ring

WH = White (Standard White Plastic)

Options

EM = Emergency battery backup

DONGLE-ISO1.0 = For use with 0-10V Electronic Relay Dimming Systems. Use 1 Dongle for each fixture dimmed.

** Consult factory for other Color Temperatures and Finishes