

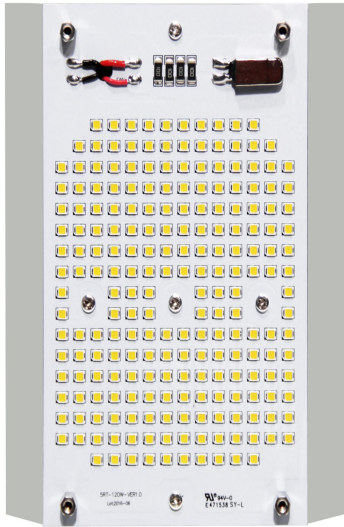

# The 5th Generation LED Retrofit kits

## New Retrofit kits Second Life to Existing fixtures



### DESCRIPTION

Our 5th generation LED retrofit kit is an innovative and revolutionary product. It is the most efficient LED retrofit kit, which is perfect for replacing almost all Metal Halide or HPS high wattage lamps. It saves up to 80% in electric, and eliminates your lighting maintenance for 10+ years, by utilizing the highest quality LED chips, drivers, heat sinks, thermal pad, PCB boards, mounting arms etc.

With the innovative mounting arm design, the installation is much easier than before. The 5th generation LED retrofit kits work for many applications including parking lot lights, wall packs, canopies, high bays, street lights, flood lights etc.

### COMPLIANCE

- \* IES /LM79/LM80 available
- \* CE ROHS Available

### FEATURES

- Long L90 lifetime: using Nichia's latest LED technology, the L90 life is 60% longer than Philips 3030 LEDs.
- Qualified driver: one of our subsidiary corporations is a Mean Well distributor, allowing us quality source for Mean well drivers.
- Lower profile heat sink design, more slim;
- Fan (fans) on the side blow(s) the heat sink in a much more efficient way (no leaking air flow).
- New mounting design: allowing for quicker installation than previous generation (saving time of more than 30%).
- Stronger mounting arm: more durable for harsh outdoor environments.
- Sensor options: photocell and motion sensor are optional for 5th gen. items.

### SENSOR

- 120VAC/100-277VAC twist-lock photocell sensor: Applicable to control passage lighting and doorway lighting automatically in accordance with the ambient lighting level. Operating temperature of -40°C~+70°C.

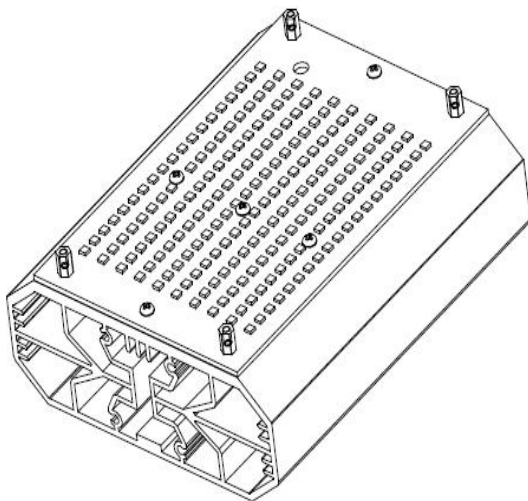

\* This product, or selected versions of this product, meet the standards listed below. Please consult factory for your specific requirements.



# The 5th Generation LED Retrofit kits

## SPECIFICATIONS

Items	Details
Model No.	VGI-5RFB-100-50[-P, -M, or blank]
Input Power	100W
Input Voltage	AC 100-277V, 50~60Hz
Luminous Flux	13,123 lm(in fixture) @5000K
Efficiency	131.3 lm/W(in fixture) @5000K
LED Source	Latest Nichia LED chips
Color Temp.:	4000K/4500K/5000K
CRI	≥73
Driver	Mean Well driver
Power Factor	>0.9306
Fixture Surface	Powder coating appearance
Dimmable	Optional
Operating Temp	- 25°C to 55°C
Replacement	400W MH/HPS
Energy saving	60% ~ 80%
Sensors	120-277V Photocell, Motion sensor available
Fan	Sunon
Testing Reports	LM79, LM80, IES available
Warranty	5-year on driver, 10-year on LED head
Qualifications	ETL/cETL, DLC premium

## Ordering Guide

EXAMPLE: VGI-5RFB-100-50[-P, -M, or blank]

Light type	Wattage	Voltage	CCT	Dimmable	Photocell sensor	Motion sensor
V5RFB=LED Retrofit kits	100=100W	Blank=100-277V HV=347-480V	40=4000K 45=4500K 50=5000K	D=Dimmable Blank= Non Dimmable	P=Photocell sensor Blank= Non Photocell sensor	M=Motion sensor Blank= Non Motion sensor

# The 5th Generation LED Retrofit kits

## INSTALLATION

### IMPORTANT SAFEGUARDS

When using electrical equipment, basic safety precautions should always be followed including the following:

### PRIOR TO INSTALLATION

1. Turn off power supply to avoid the risk of electrical shock.
2. Proper grounding is required to ensure personal safety.
3. Make certain power is OFF before starting installation or maintenance.
4. Do not recess the fixture.
5. A qualified electrician should do all work.
6. DO NOT TOUCH THE LED CHIPS. DAMAGE MAY OCCUR.

## MOUNTING OPTIONS