

# Solar LED Square Bollard Light

Wattages: 5W



The working principle of Solar LED Square Bollard Light: The solar panel is irradiated by sunlight, absorbs the sun light and converts it into electric energy to charge the battery. At night, the battery pack provides power to supply the LED lighting to realize the illumination.

The DC controller can ensure that the battery pack is not damaged due to overcharging or overdischarging, meanwhile, it has temperature compensation and lightning protection, reverse polarity protection and other functions such as Light control, lighting 3-5 rainy days.

Ideal for parks, apartments, residences, lawns, courtyards, roadways and many other applications.



## FEATURES:

- High luminous efficiency and long working life.
- A special solar controller is used.
- Osram light source chip is used.
- Monocrystalline silicon solar panel.
- Excellent optics design, greatly improve the light utilization and evenness.



SPECIFICATION	
TYPE	VE-SPSBL5W5-50K-B
WATTAGE	5W
CCT	5000K
LUMEN	1896.3 LM
CRI	80
MATERIAL	Die-casting aluminum
SOLAR PANELS	5V/5W
BATTERY	3.2V/8000mAh
CHIP	OSRAM 3030
LAMP SIZE	7.87 X7.87 X 9.45 inch
WORKING TIME	8H
CHARGING TIME	3-5H
WORKING TEMPERATURE	-4°F ~ 122°F
CABLE	NO
OUTDOOR RATING	IP65
WARRANTY	2 year limited

**Wattages: 5W**

**DIMENSION**

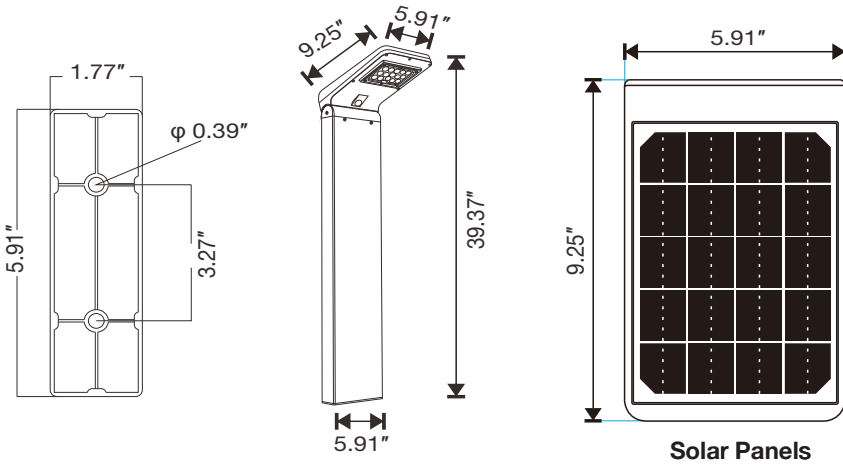

**PACKAGING INFORMATION**

❖WSD-SPSBL5W5-50K-B

**INNER BOX:**

940MMX160MMX150MM(1Pcs/CTN)  
(37.01" X6.30" X5.91" )

**OUTER BOX:**

960MMX680MMX330MM(8Pcs/CTN)  
(37.80" X26.77" X12.99" )

**SPECIFICATIONS:**

Shell materials: Aluminum & PC

Net weight : 6.55 lbs

Finish: Black(Standard)

Product Size:235 X 150X1000(mm)

9.25"X5.91"X39.37"

** Solar lawn lamp-switch control mode**

- 1 Press the switch button once (PIR motion sensor)
- 2 Press the switch button twice (constant mode)
- 3 Press the switch button three times (turn off)

20% brightness  
when people leave



# Wattages: 5W

## ACCESSORIES (Standard)



Expansion Screw



SCREW

---

## ORDERING INFORMATION

EXAMPLE:

**VE-SPSBL5W5-50K-Z[D, W, B, S]**

VE	SPSBL	5W	5	50K	Z
COMPANY	PRODUCT	WATTAGE	VOLTAGE	CCT	FINISH
	SPSBL (Solar LED Square Bollard Light)	5W - (5W)	5 - (5V)	50K - (5000K)	D - (Dark Bronze) W - (White) B - (Black) S - (Silver)