

VBRK-LED48ARC8-4K

8" Commercial Grade Retrofit Downlight



STANDARD



VBRK-LED luminaires are commercial-grade retrofit kits, which convert nearly any existing incandescent, HID or CFL luminaire to LED. These luminaires offer substantial energy savings, and expected life of 50,000 hours.

FEATURES

- Installs from below ceiling.
- Conduit quick-connect connectors facilitate installation.
- Consistent luminaire-to-luminaire color temperature within 3 MacAdam Ellipses.
- Integral heat sink conducts heat away from LED light engine.
- Driver is accessible from below the ceiling and can be upgraded to accommodate future technology improvements.
- LED driver accommodates 120V - 277V inputs (50/60Hz) with 0-10V dimming standard.
- Available in 3000k (40W model) and 4000k (48W model).
- Color rendering index (CRI) ≥ 80 .
- Long life LED's provide expected life of 50,000 hours.



WARRANTY & LISTINGS

- cULus approved for damp locations
- Operating Temp -30°C to 40°C / -22°F to 104°F
- Energy star qualified
- Title 24 Compliant
- RoHS Compliant
- 5-year warranty of all electronics and housing.

DIMENSIONS

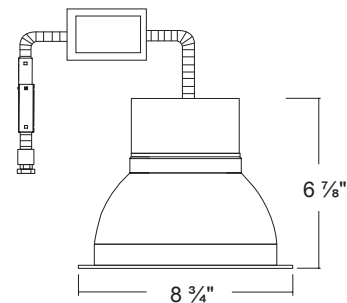

ORDERING INFORMATION

Model	Color Temperature	Luminaire Lumens	Luminaire Watts	Lumens / Watt
VBRK-LED40ARC8-3K	3000k	3,030	40	76
VBRK-LED48ARC8-4K	4000k	3,560	48	74