

# VBRK-LED28ARC6-3K VBRK-LED40ARC6-4K

# 6" Commercial Grade Retrofit Downlight



## STANDARD



VBRK-LED luminaires are commercial-grade retrofit kits, which convert nearly any existing incandescent, HID or CFL luminaire to LED. These luminaires offer substantial energy savings, and expected life of 50,000 hours.

## FEATURES

- Installs from below ceiling.
- Conduit quick-connect connectors facilitate installation.
- Consistent luminaire-to-luminaire color temperature within 3 MacAdam Ellipses.
- Integral heat sink conducts heat away from LED light engine.
- Driver is accessible from below the ceiling and can be upgraded to accommodate future technology improvements.
- LED driver accommodates 120V - 277V inputs (50/60Hz) with 0-10V dimming standard.
- Available in 3000k (28W model) and 4000k (40W model).
- Color rendering index (CRI)  $\geq 80$ .
- Long life LED's provide expected life of 50,000 hours.



## WARRANTY & LISTINGS

- cULus approved for damp locations
- Operating Temp -30 °C to 40°C / -22°F to 104°F
- Energy star qualified
- Title 24 Compliant
- RoHS Compliant
- 5-year warranty of all electronics and housing.

## DIMENSIONS

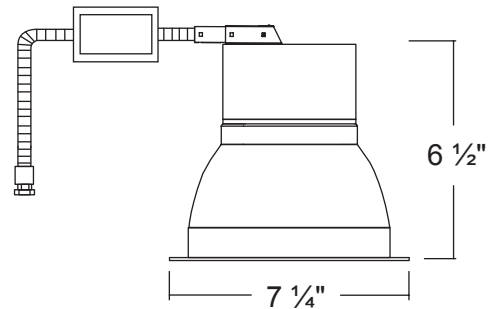

## ORDERING INFORMATION

Model	Color Temperature	Luminaire Lumens	Luminaire Watts	Lumens / Watt
VBRK-LED28ARC6-3K	3000k	2,210	28	79
VBRK-LED40ARC6-4K	4000k	2,980	40	75