

# VBRK-LED21ARC4-3K

## 4" Commercial Grade Retrofit Downlight

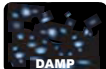

### STANDARD



VBRK-LED luminaires are commercial-grade retrofit kits, which convert nearly any existing incandescent, HID or CFL luminaire to LED. These luminaires offer substantial energy savings, and expected life of 50,000 hours.

### FEATURES

- Installs from below ceiling.
- Conduit quick-connect connectors facilitate installation.
- Consistent luminaire-to-luminaire color temperature within 3 MacAdam Ellipses.
- Integral heat sink conducts heat away from LED light engine.
- Driver is accessible from below the ceiling and can be upgraded to accommodate future technology improvements.
- LED driver accommodates 120V - 277V inputs (50/60Hz) with 0-10V dimming standard.
- Available in 3000k (21W model).
- Color rendering index (CRI)  $\geq 80$ .
- Long life LED's provide expected life of 50,000 hours.



### WARRANTY & LISTINGS

- cULus approved for damp locations
- Operating Temp  $-30^{\circ}\text{C}$  to  $40^{\circ}\text{C}$  /  $-22^{\circ}\text{F}$  to  $104^{\circ}\text{F}$
- Energy star qualified
- Title 24 Compliant
- RoHS Compliant
- 5-year warranty of all electronics and housing.

### DIMENSIONS

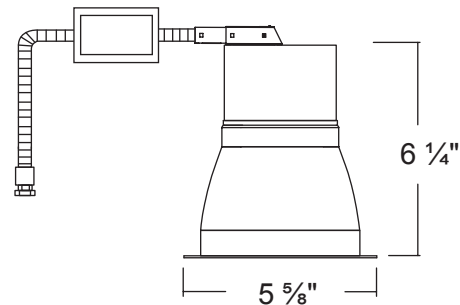

### ORDERING INFORMATION

Model	Color Temperature	Luminaire Lumens	Luminaire Watts	Lumens / Watt
VBRK-LED21ARC4-3K	3000k	1,590	21	76