

Model: VESBL47 Loutus100*100

Solar LED Brick 100x100x47mm



Patented product



- ◆ **Waterproof:** Original triple structure with glue waterproof patent, private mold waterproof connector and reliable waterproof performance, up to IP67-IP68;
- ◆ **Texture:** Surface texture hardness up to 5°, anti-scratch, anti-wear, acid & alkali resistant, customizable texture and pattern;
- ◆ **Customization:** Customizable size & shape;
- ◆ **Application:** Municipal and commercial squares, garden paths, cultural tourism projects, etc.

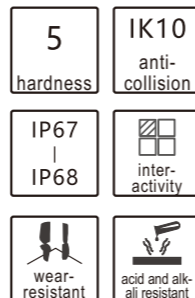

◆ Specification

LED Type : Lumileds
Power Rating : 0.5W
Color Temperature: 3000K, R, G, B
Life Span : ≥50000 hrs
Housing: PC transparent cover
Dimension : 100x100x47mm
Weight : 0.5kg
Battery: 2200mAh lithium battery
Charging time: 20hrs (sunny day)
Discharge time: 3 nights and above (full charged)
Working Temperature: -10°C ~ +45°C
Control: ON/OFF
Ingress Protection: IP67
Classification: Class III
Installation: Embedded buried installation

◆ Project Cases

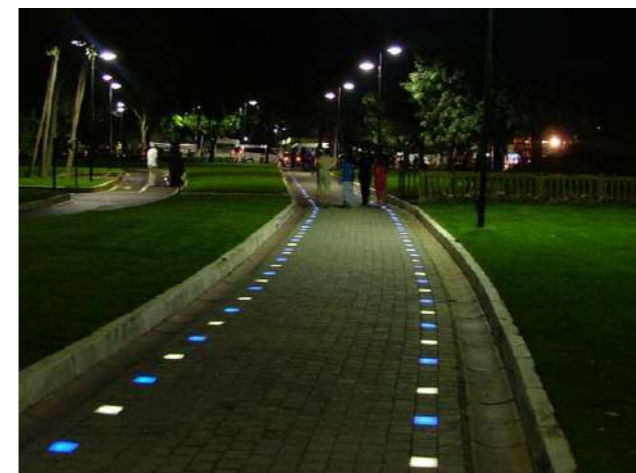

◆ Size

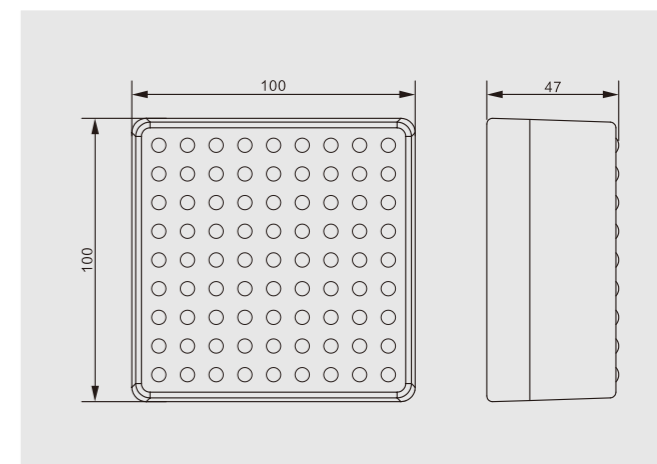

◆ Installation

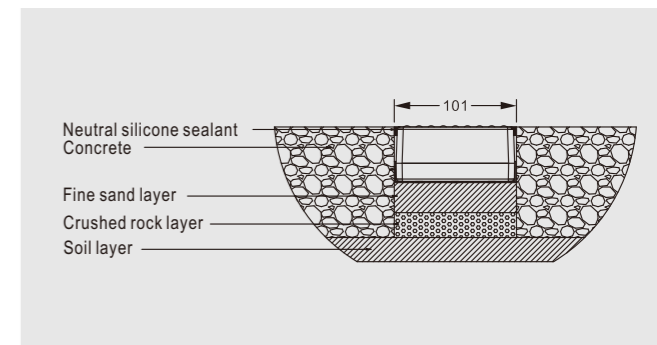

◆ Fixture Options

Spec	Size	Texture	LED color	Battery	Power	Control	Other options
100x100	100x100x47mm	Dots, Snowflake, Fish, etc	3000K, R, G, B	2200mAh	0.5W	ON/OFF	Drive over

* The contents and parameters of this product are for informational purposes only, subject to change without any notice, please refer to real product, our company reserves the final interpretation.