

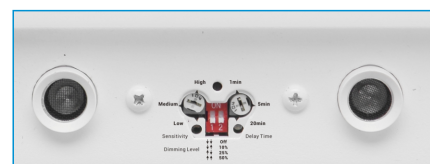

LED Stairwell Light

Product Features

- 35/45/55W Power Selectable
- 35K/40K/50K CCT Selectable
- Built-in MCWONG Ultrasonic Sensor
- Built-in 10W EM Battery model available
- High lumen efficiency up to 130LPW, DLC 5.1 Premium Listed
- UL 1598 Listed for damp locations
- UL 8750 LED equipment in lighting products
- 0-10V continuously dimmable, dim down to 10%
- Flicker Rate < 10%
- Wall mounting configuration
- 5 years warranty



Application

Stairwell, Hallways, Corridors, Closets, Pathways...

Ordering Number Logic

| Model Number | Watt | Efficacy | CCT | Voltage | DIM | Sensor | EM Battery |
|---------------------------------|----------------------|----------|----------------------|-------------|-------|-------------------|----------------|
| VE55STW0/4FTLED35/40/50S | 35/45/55W Selectable | 130LPW | 35/40/50K Selectable | 120-277V AC | 0-10V | Ultrasonic Sensor | N/A |
| VE55STW0/4FTLED35/40/50E | 35/45/55W Selectable | 130LPW | 35/40/50K Selectable | 120-277V AC | 0-10V | Ultrasonic Sensor | 10W EM Battery |

Line Drawings

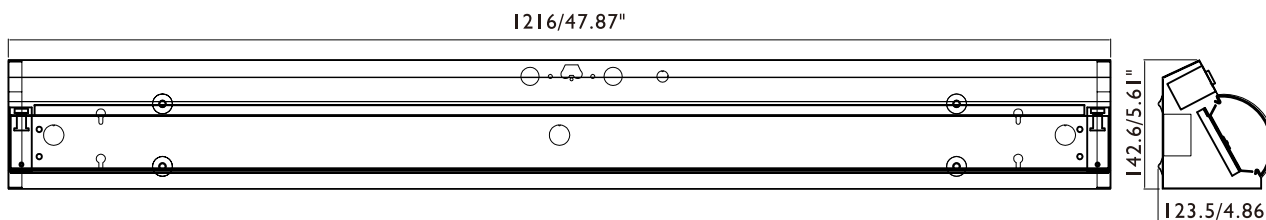
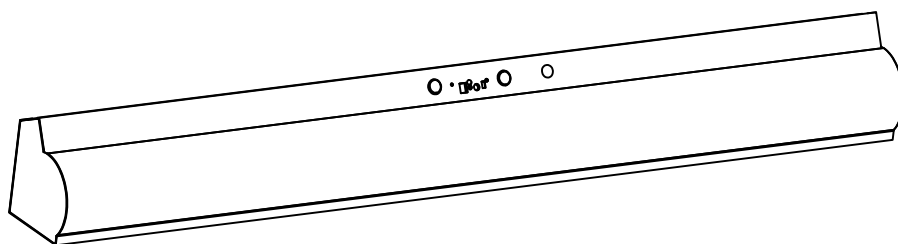

LED Stairwell Light

Sensor Specifications

| | |
|---|---|
| Sensor Type | Ultrasonic occupancy sensor |
| Input Voltage Current Consumption | 12-24VDC 45mA sensor |
| 0-10V Output | 100mA, up to 50LED sink drivers |
| High | Vin-2.5V 100mA source |
| Low | 100mA sink current |
| Mounting Height | Fixture-Wall Mount or ceiling mount at 8-12ft(2.4-3.7m)high |
| [Low/Med/High] Max Range (Wall Mounted) | 13ft(4.0m)/18ft(5.5m)/35ft(10.7m) |
| Time Delays | 1min, 5min, 20min |
| Sensitivity | Low, Medium, High |
| Dimming Level | Off, 10%, 25%, 50% |
| Operating Temperature | -30°C to 70°C |
| Storage Temperature | -40°C to 80°C |
| Relative Humidity | 90-95% non-condensing at 30°C |
| Color | White |
| Warranty | 5 years |

Dimension

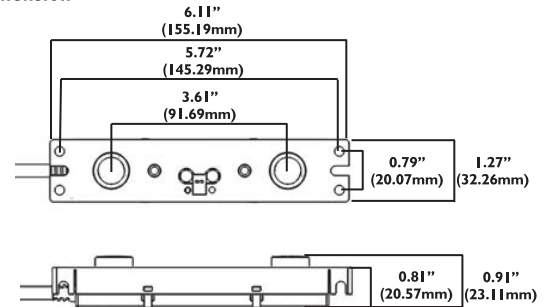

Detection Pattern

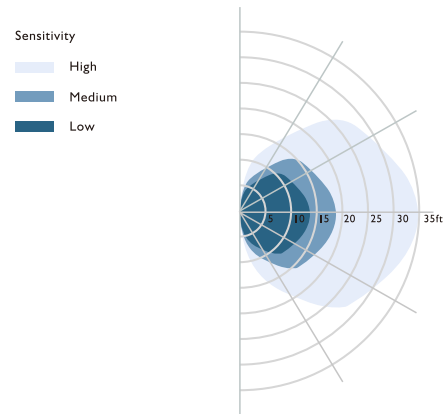

Emergency Specification

| | |
|------------------------------|-----------------|
| Input Voltage (range) | 120V-277V |
| Power Factor | 0.6 @ 277V |
| Input AC current (max @ VAC) | 100mA |
| Output Power (max.) | 10W |
| Recharge Time Req. | 24 hours |
| Recharge current | 0-450mA |
| Battery type | LiCoMnNiO2 |
| Illumination Time | 90 minutes min. |
| Total Max LED powered | 10W |
| Ambient Temperature | 0°C -50°C |
| Design Life | 50000 hours |

Wiring Diagram

