

SHV-LED8WP

120VAC LED DoB Exterior Step Light

LED

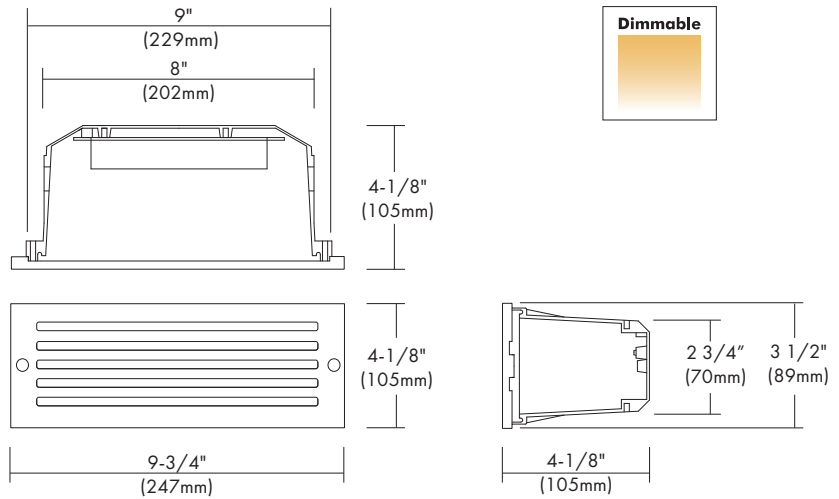

DESCRIPTION

The SHV-LED8WP is designed with state-of-the-art LED DoB technology and is sealed for outdoor use. The Step Light contains 20 LEDs, ideally spaced to produce bright, even illumination. Engineered with superior thermal management, it provides economical, long lasting performance and trouble free operation. Suitable for Wet Locations.

DESIGN FEATURES

Housing & Trims

- Cast aluminum housing with trim painted with weather proof white, black or silver.

Electronics

- 120V AC Direct DoB technology; 20 LED chips for 5W of power (~400lm).

Illumination

- 80 CRI with a color temperature of 3000K Standard. Contact factory for other CRI and Color Temperatures.

Limited Warranty

- LED Module: 5 years/50K hours
- Product: 3 years

Listing

- cCSAus Wet Location

TRIM



Louvered face plate

ST-844-WH
ST-844-BK
ST-844-SI



Open face plate

ST-845-WH
ST-845-BK
ST-845-SI



Grilled face plate

ST-846-WH
ST-846-BK
ST-846-SI

Ordering Information

Model	-Trims	-Finish
SHV-LED8WP 120VAC, DoB 5W Exterior Step Light	<ul style="list-style-type: none"> -ST-844 = Louvered -ST-845 = Open -ST-846 = Grilled 	<ul style="list-style-type: none"> -WH = White -BK = Black -SI = Silver

Example : SH-LED8WP-ST-844-WH